

Dimensions in Inches, Tolerances: .XX ± .03 .XXX ± .010

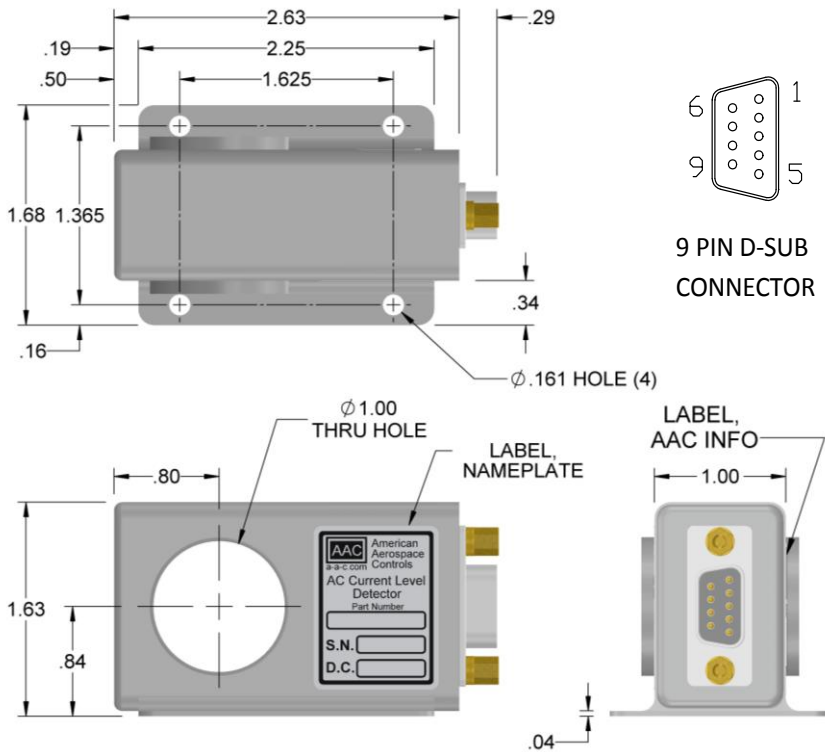

9 PIN D-SUB CONNECTOR

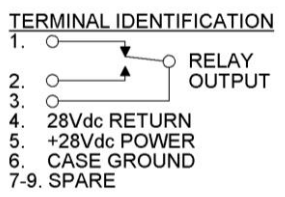

Crash Safety (Sustained) Test Performed IAW RTCA DO-160G, Section 7 at below levels					
Test Levels	FWD	AFT	LAT	UP	DOWN
Sustained	27.21g	N/A	6.8g	4.54g	N/A

Operational Shock & Crash Safety (Impulse) Test Performed IAW RTCA DO-160G, Section 7, Category E

Constant Acceleration Test Performed IAW Mil-Std-810G Method 513 at below levels					
Propeller Aircraft Environment					
Test Levels	FWD	AFT	LAT	UP	DOWN
Operational	1.7g	2.9g	5.75g	4.25g	11.5g
Structural	2.55g	4.35g	8.65g	6.37g	17.25g
Helicopter Environment - Operating @ Structural Levels					
Test Levels	FWD	AFT	LAT	UP	DOWN
Operating	4.0g	4.0g	6.0g	10.5g	4.5g

CONTACTS SHOWN WITH INPUT CURRENT ABOVE TRIP POINT (RELAY ENERGIZED)

Additional Vibration Compliance: Category 13 Propeller Aircraft
Vibration Exposure Performed I.A.W MIL-STD-810G, Method 514.6, Figure 514.6 D2, Procedure I

Trip point option from 1A to 250Aac in 1 amp increments. Time delay option 1 to 10 sec. in 1 sec. increments

AC CURRENT LEVEL DETECTOR (Time Delay) SERIES S1062

INPUT

RANGE..... 0 to 250Aac
 FREQUENCY RANGE..... 360Hz to 650Hz
 OVERLOAD CURRENT CONTINUOUS..... 500Aac
 OVERLOAD CURRENT SURGE..... 1000Aac for 6 cycles.

OUTPUT RELAY

RELAY CONTACT (SPST)..... Energized at & above trip point
 CONTACT RATING..... 1 Amp Resistive, @ 28Vdc. 100mA @28V Lamp
 200mA Inductive @28Vdc (320mH)
 250mA @ 115Vac 60 Hz to 400Hz
 TRIP POINT (AS CURRENT INCREASES)..... 1Aac to 250Aac (See Ordering Information)
 TRIP POINT ACCURACY..... ±1% of trip point. (See note 1)
 CURRENT CABLE POSITIONING ERROR..... ±0.1% of trip point max. for cable Dia. of .25 inch
 RESET..... Automatic @ 20% below trip point.
 RESPONSE TIME (@110% of trip point)..... 1 to 10 sec. (See Ordering Information)
 OUTPUT ISOLATION..... 350V RMS

POWER SUPPLY

SUPPLY VOLTAGE..... 28Vdc, Nominal
 SUPPLY VOLTAGE RANGE..... 20.5Vdc to 32.2Vdc max
 CURRENT DRAIN..... 20mA max.
 REVERSE POLARITY PROTECTION..... 100µA max. current drain without damage

ENVIRONMENTAL AND PHYSICAL CHARACTERISTICS

OPERATING & STORAGE TEMP RANGE..... -55°C to +85°C
 DIELECTRIC STRENGTH..... 350V DC MIL-STD-202 Method 301
 MOUNTING..... Rigid in any position
 INSULATION RESISTANCE (Test A)..... 200 M-Ohms min. MIL-STD-202 Method 302 Test Condition A
 WEIGHT..... 9 oz. Max.
 FINISH..... Fuse tin plate (lead alloy 4% to 12%max.)

DO-160E ENVIRONMENT

TEMPERATURE & ALTITUDE
 TEMPERATURE VARIATION
 HUMIDITY
 SHOCK & CRASH SAFETY
 VIBRATION
 EXPLOSION PROOFNESS
 WATER PROOFNESS
 SAND & DUST
 FUNGUS RESISTANCE
 SALT FOG
 ICING
 MAGNETIC EFFECT
 POWER INPUT
 FIRE FLAMMABILITY
 VOLTAGE SPIKES
 AUDIO FREQUENCY CONDUCTED
 INDUCED SIGNAL SUSCEPTIBILITY
 RF SUSCEPTIBILITY
 EMISSION OF RADIO FREQUENCY
 LIGHTNING INDUCED TRANSIENT
 ELECTROSTATIC DISCHARGE (ESD)

SECTION

4
 5
 6
 7
 8
 9
 10
 12
 13
 14
 24
 15
 16
 26
 17
 18
 19
 20
 21
 22
 25

CATEGORY

B2 & D2
 A & B
 B
 D & E
 U2
 H
 Y
 D
 Y
 Z
 B & Z
 C
 A
 B
 ZC
 R
 M
 A3G33
 A

ORDERING INFORMATION

SERIES → S1062- - -
 TRIP POINT AMPS AC ↑ TIME DELAY SEC.

i.e.: S1062-100-3 Current Level Detector trips @ 100Aac and reset @ 80Aac with a Trip time delay of 3 sec.

Note 1: Specified accuracy includes the combined worst case effects of Current Cable Positioning, Voltage Range, Temperature Range and Input Frequency Range.

AAC	Drawing Number S1062-850	Rev. B
------------	---	-------------------------